



Wood chip, shaving and pellet boiler

# Lambdamat

750 - 1500 kW



# High-tech without limits

For more than 50 years Froling has specialised in the efficient use of wood as a source of energy. Today the name Froling stands for modern biomass heating technology. Our firewood, wood chip and pellet boilers are successfully in operation all over Europe.

All of our products are manufactured in company-owned factories in Austria and Germany.

Froling's extensive service network ensures that we can handle all inquiries quickly.



## Wood chips, shavings, pellets and more



**Wood chips** are a local and environmentally-friendly fuel which is not subject to the crises and fluctuations of the market. Furthermore, wood chip production provides jobs for local residents. Therefore wood chips are the perfect fuel, not just economically, but also from an ecological standpoint. Leftover branches and treetops and sawmill waste are shredded into wood chips. The quality class is determined by the type of wood used.

**Wood pellets** are made of natural wood. The large quantity of wood shavings and sawdust produced by the industry are compacted and pelleted without being treated beforehand. Pellets have a high energy output and are easy to deliver and store. These are just some of the advantages that make pellets the perfect fuel for fully automatic heating systems. Pellets are delivered by tanker and unloaded directly into your store.



**Shavings** are a waste material and a by-product of the wood-processing industry, and are therefore the logical fuel for this industry. The characteristics of this exceptionally dry heating material require particularly robust combustion technology.

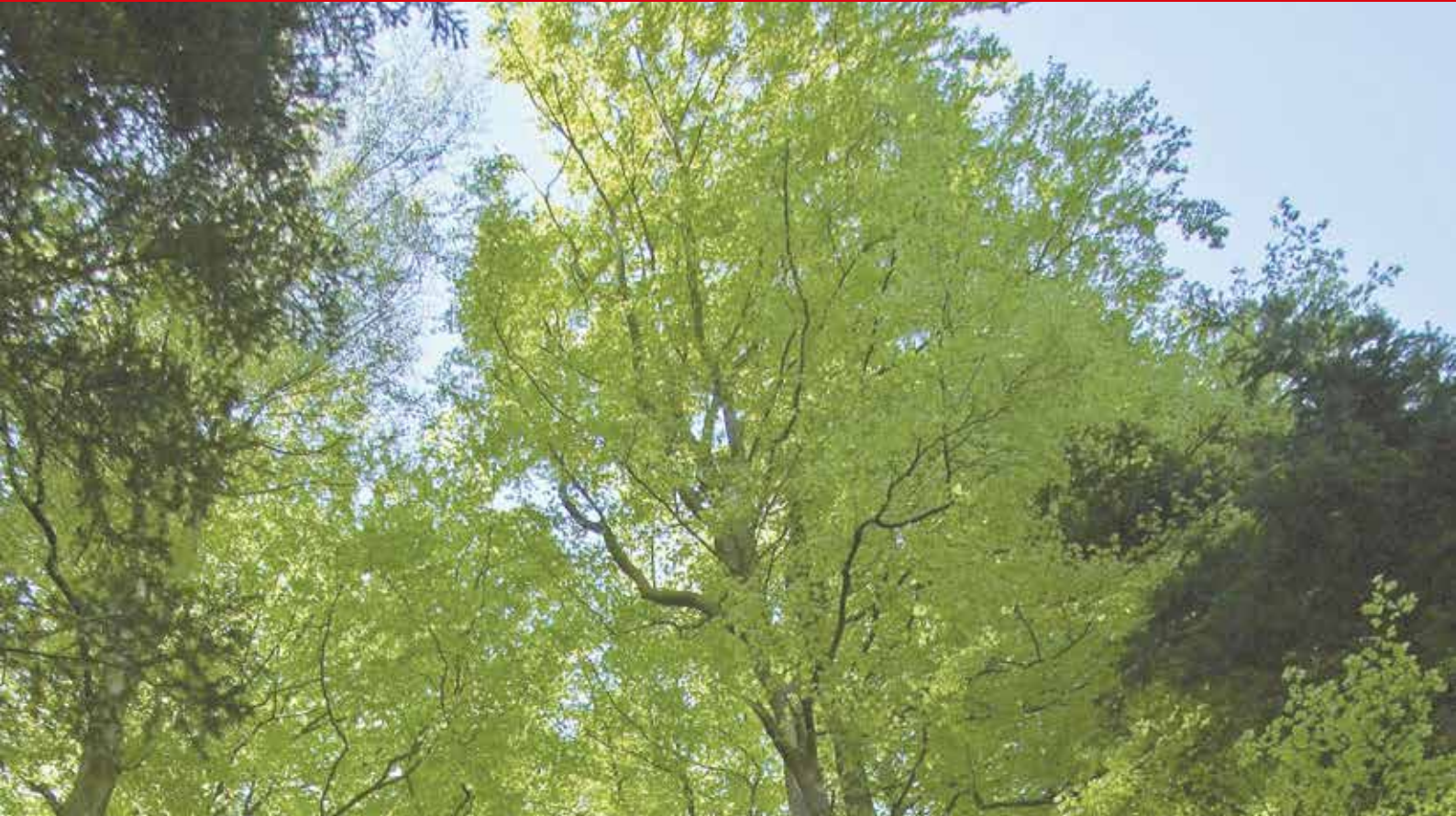

## The result of systematic research and development!

Froling's Lambdamat is a unique, fully automatic heating system for burning wood chips, shavings and pellets. It not only offers innovative combustion technology, but also a high level of convenience and operational reliability. The boiler sizes in the "Communal" version are suited to fuels with a water content of up to 50%.

Thanks to the special combustion chamber shape, Froling's Lambdamat is perfect for burning fuels of different qualities and with a high bark content. The hydraulic moving grate continuously transports the fuel through the combustion chamber, ensuring that even heavy fuels are completely burned. In addition to fuel loading by feed screws, this boiler technology can also be supplied with a hydraulic feed system.



# Robust technology with smart details



## Highlights:

- 1 Multifunctional heat exchanger which features large heat exchanger surfaces. Convenient maintenance is ensured by large and easy to reach cleaning and maintenance openings.
- 2 Multi-layer high temperature chamotte combustion chamber for high efficiency and clean combustion.
- 3 The hydraulically operated moving grate with primary air intake system keeps the fuel moving continuously and ensures complete burn-out (even with heavy fuels).
- 4 Fully automatic ash removal.
- 5 The secondary air openings ensure optimum combustion and a complete burn-out.
- 6 Tertiary air vents for increased efficiency during combustion. The fully controlled flue gas recirculation AGR (optional) optimises burning (output, emissions etc.) with particularly demanding fuels.
- 7 The double tunnel vault guarantees the optimum burn-out of fuels with a high water content.
- 8 Compressed air heat exchanger cleaning
- 9 Automatic ignition

**Feature: High-temperature combustion chamber with moving grate**

- Advantages:
- No cinder build-up
  - Optimum burnout
  - Very low emissions
  - Automatic ash removal

The high-temperature combustion chamber is four-shelled, guaranteeing clean combustion. The jacket cooling and the water-cooled stoker duct minimise radiant heat losses and guarantee high efficiency. Thanks to the moving grate, boiler operation is reliable and maintenance-free, even when using low-grade fuels which tend to form cinder. Separation of the primary air zone guarantees optimum burnout. This keeps emission levels very low (CO less than 10 mg/MJ). The ashes that fall under the grate are automatically transported to the ash container by a rake.

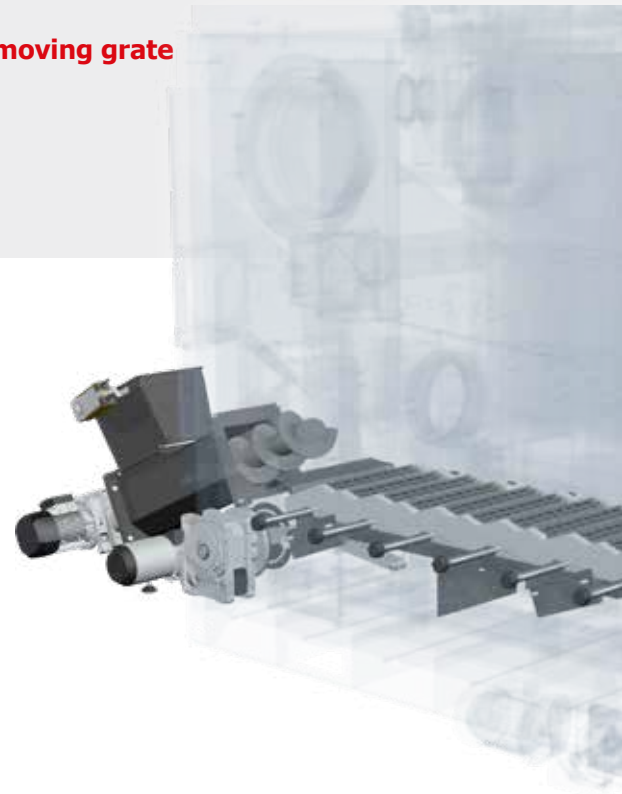

**Feature: Flue gas recirculation**

- Advantages:
- Combustion optimisation
  - Preserves the flame-swept parts

Some of the flue gas is fed back into the combustion by a speed-regulated FGR blower fan. The residual oxygen in the flue gas is fed back to the combustion zone by automatic progressive rotary slide valves serving as the primary and secondary flue gas return. This reduces the NO<sub>x</sub> emissions. It also helps to protect the fireclay when high-quality dry fuels are used whilst optimising combustion and output for both damp and dry fuels.

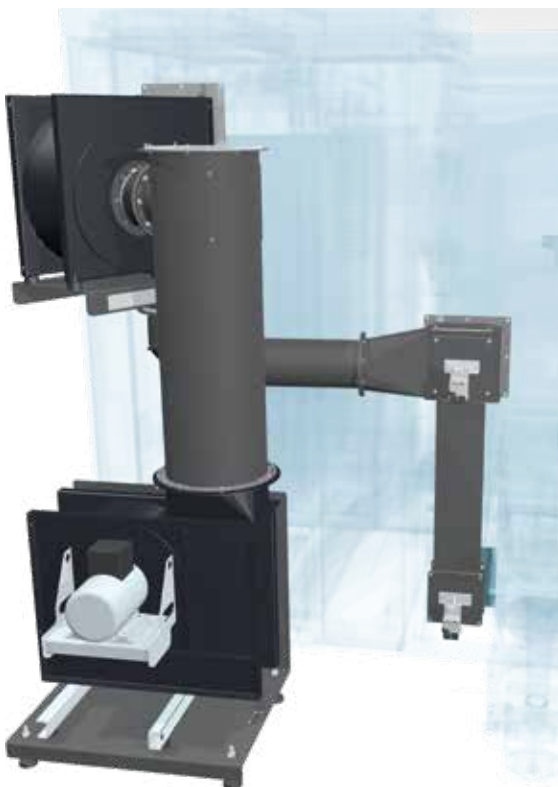

# Systematic convenience



## **Feature: Froling SPS 4000 controller**

- Advantages:
- Powerful SPS controller with 5.7" colour touch display
  - Safe and simple remote access via Froling visualisation software
  - Numerous functional options

The SPS 4000 is made up of high-quality industry-standard components. The clear, user-friendly control system offers a wide range of different settings and display options for individual, efficient and stable operation.

The Froling SPS 4000 offers numerous functional options such as five-sensor storage tank management, heating circuit and network temperature control, external power specifications, cascade function, integration, monitoring and control of additional peripheral components.



## **Feature: Froling visualisation software**

- Advantages:
- Monitor and operate from your PC
  - Record boiler data

The boiler display software available enables convenient remote control of the system from a computer. All operating values and customer parameters can be displayed and modified. The familiar Windows interface and clear menu structure make it easy to use.

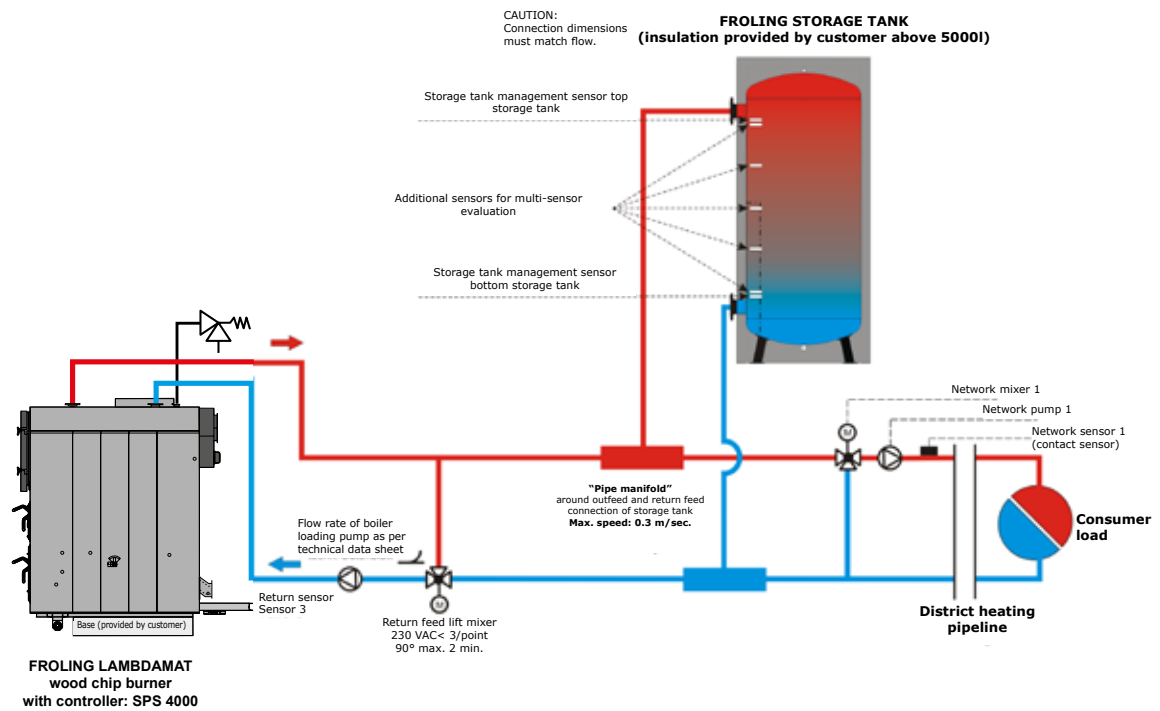
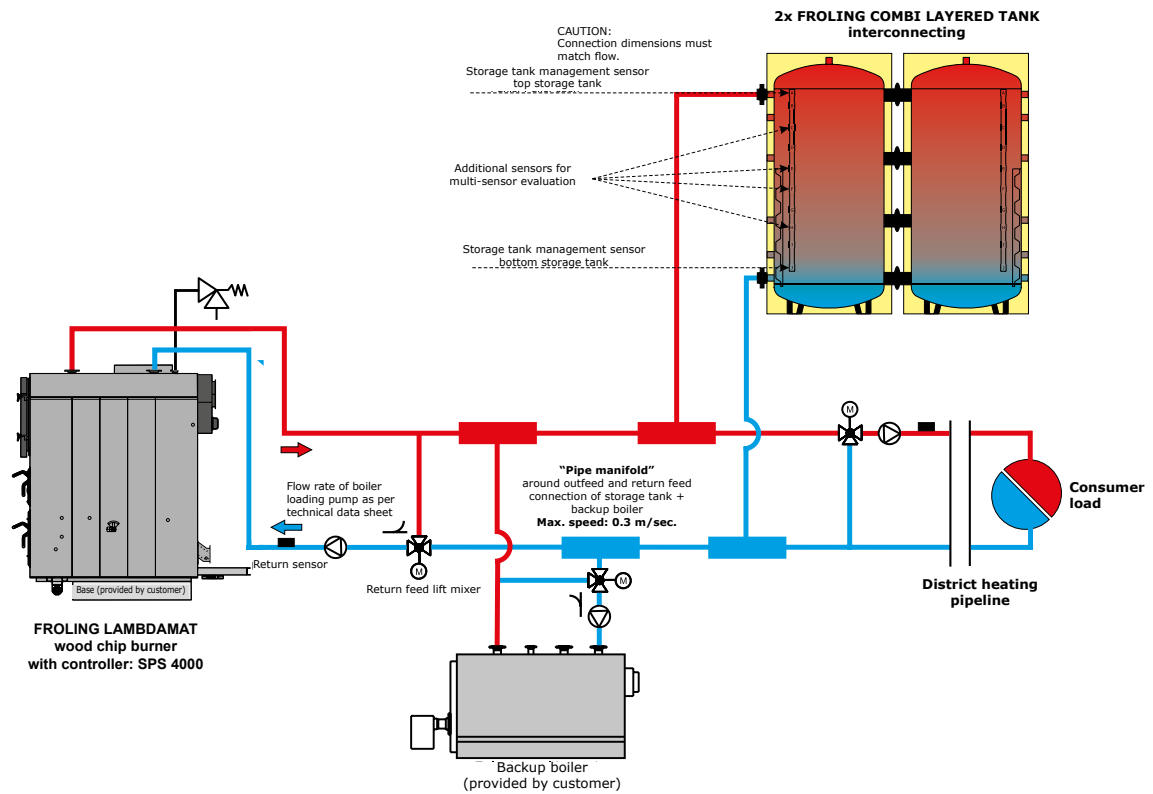

# Fuel discharge systems

## Froling discharge systems - design development perfected over decades

Froling has expertise designing discharge systems spanning many years. Whether the system is large or small, Froling provides sturdy feeder systems, which meet the highest technical standards. For example, the Lambdamat Communal can be connected to a hydraulic feeder system, which is ideal for bulky or bundled fuels.

### Torsion arm agitator (TGR)



For discharge of fuels from bunkers with a maximum working diameter of 6 metres. The system is low maintenance and is especially designed for fuels with increased discharged output due to their limited ability to flow. The patented design guarantees quiet and effective operation. The feed screw with progressive screw blade ensures low energy consumption.

### Inclined screw feeding unit



Mainly used as a silo discharge screw in the wood-processing industry. Provides even and reliable fuel discharge from high silos.

### Horizontal screw feeding unit



Sturdy construction to take in extremely high feed loads when discharging from high silos. Especially designed for shavings and large diameter bunkers.

### Sliding floor feeding unit



Optional design for rectangular storage rooms. Suitable for all common biomass fuels. The sliding floor feeding unit is extremely sturdy and has proven to be specifically suitable for discharging fuels from large wood chip stores.

**Please contact our sales engineers for further details.**



# Practice proves the difference

## Gradonna Mountain Resort, Kals, Austria



A Fröling cascade system provides cosy warmth from wood at the four star superior Gradonna Mountain Resort hotel in Kals am Großglockner, Austria. The specification was to find a solution that would be able to handle a wide range of fuel qualities (dry/wet, small/large) as efficiently and as reliably as possible. Fabric filters were included to ensure optimum cleaning of the flue gas and a condenser unit was integrated to increase energy efficiency.

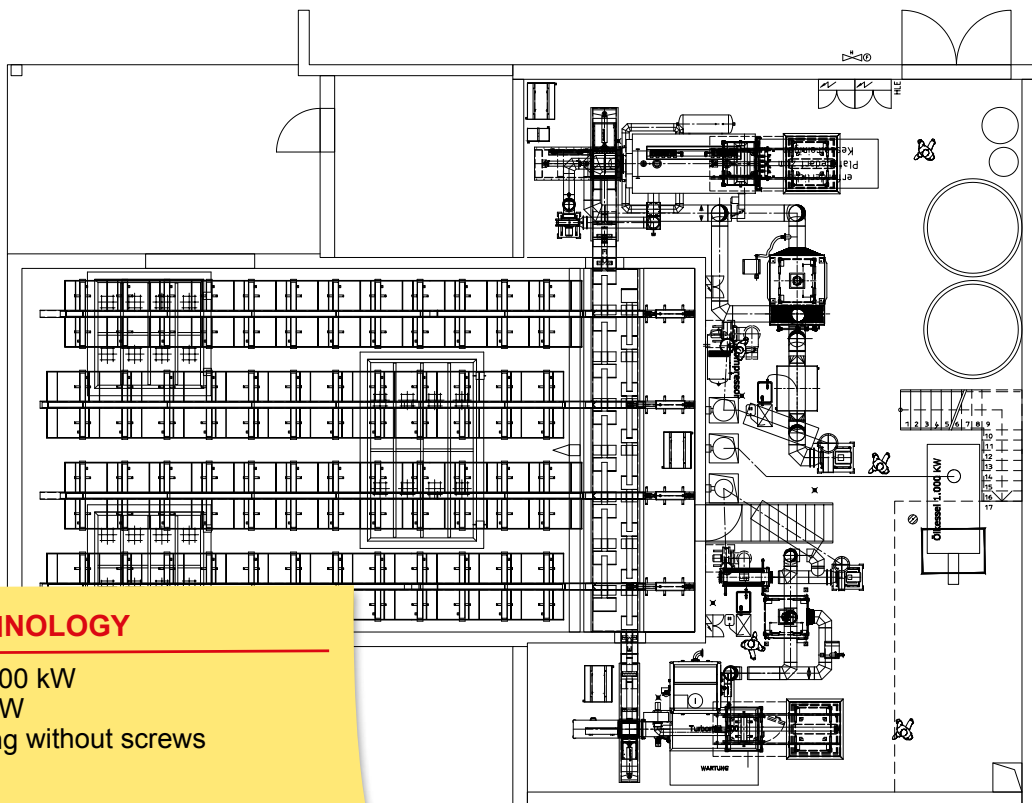

### FROLING TECHNOLOGY

- Lambdamat 1,000 kW
- Turbomat 500 kW
- Hydraulic loading without screws
- Fabric filters
- Condenser

# Practice proves the difference

## Ikea central warehouse, Wels, Austria



The Ikea name speaks for itself. It uses Froling technology to heat many of its premises. At its central warehouse in Wels 2x 1,000 kW boilers provide heat from pellets.

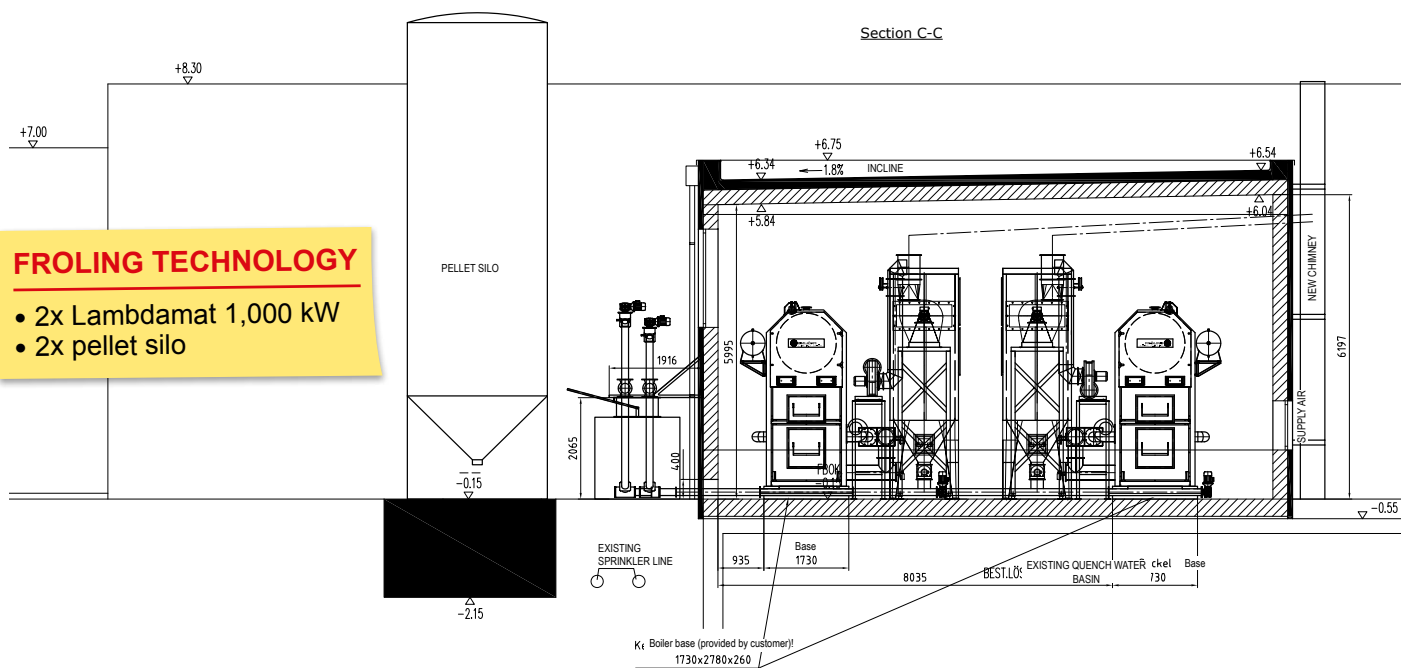

## Lambdamat Communal

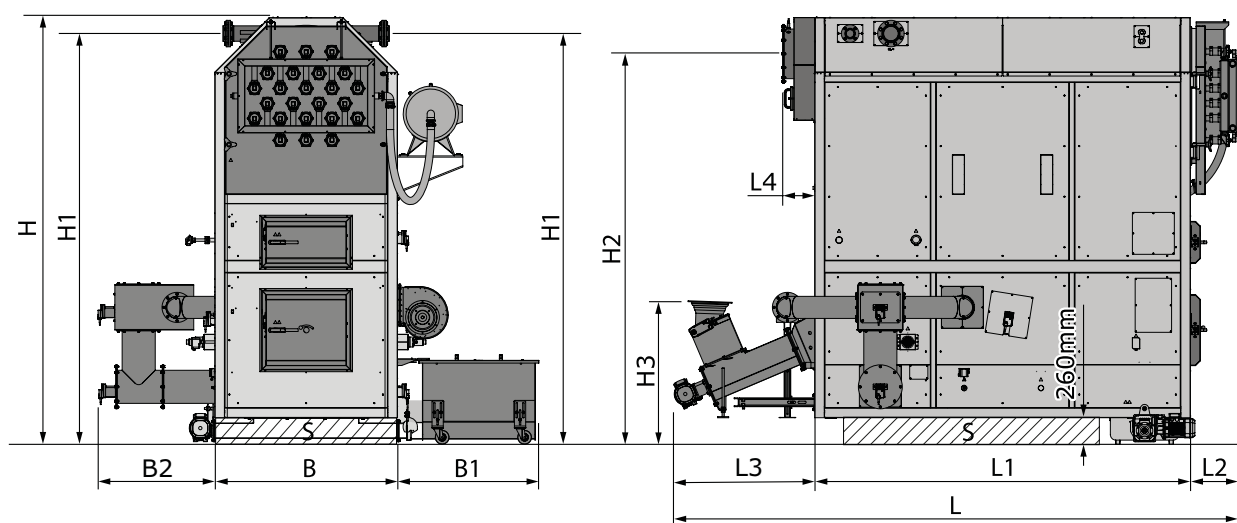

DIMENSIONS		750	1000	1500	
H	Height of boiler	[mm]	3600	3855	4585
H1	Height of flow connection / return connection	(mm)	3660	3915	4660
H2	Height of flue gas pipe connection	[mm]	3250	3570	4200
H3	Height of stoker incl. BBF	[mm]	1220	1200	1500
B	Width of boiler	[mm]	1630	1630	1850
B1	Width of ash container	[mm]	1295	1275	1295
B2	Width of FGR	[mm]	1075	1065	1075
L	Total length	[mm]	3075	3675	4360
L1	Length of boiler	[mm]	2710	3380	3935
L2	Length of compressed air cleaner	[mm]	425	430	425
L3	Length of stoker incl. gears	[mm]	1290	1290	1290
L4	Length of flue gas collection box	[mm]	255	255	500

TECHNICAL DATA		750	1000	1000 <sup>1)</sup>	1500
Nominal heat output	[kW]	750	980	1001	1500
Quantity of fuel required at nominal load	[kg/h]	242	317	324	490
Flue gas pipe diameter	[mm]	300	300	300	300
Total weight excl. fittings	[kg]	11440	14900	14900	23300
Heat exchanger water capacity	[l]	1840	2390	2390	4240
Maximum permitted operating temperature	[°C]	95 <sup>2)</sup>			
Permitted operating pressure	[bar]	6			
Flue gas temperature at nominal load / partial load	[°C]	220 / 160			

1) Only available in UK.

2) Higher temperatures available on request.

Your Froling partner:



**Heizkessel- und Behälterbau GesmbH  
A-4710 Grieskirchen, Industriestr. 12**

AT: Tel +43 (0) 7248 606 • Fax +43 (0) 7248 606-600  
GE: Tel +49 (0) 89 927 926-0 • Fax +49 (0) 89 927 926-219  
Email: [info@froeling.com](mailto:info@froeling.com) • Internet: [www.froeling.com](http://www.froeling.com)

P0370217 - All illustrations intended as a guide only.  
We reserve the right to make technical changes without prior notice. Errors and omissions excepted.  
Sources for external images: [www.aboutpixel.de](http://www.aboutpixel.de), [www.pixelio.de](http://www.pixelio.de)